

# MRC 8-16 Potato Multihead Weigher

High speed multihead weigher specially designed for potatoes.



*Check our other  
packaging solutions...*

# Features

- Central distribution cone incl. high adjustable infeed hopper & infeed control
- 8 linear product feeders
- 8 top hoppers with 2-way gating system
- 16 weigh hoppers with 100% guaranteed discharge
- Top and weigh hoppers positioned to prevent the product from damaging
- Food approved Polyethylene outfeed funnel, special design to prevent product damage
- Catch box / discharge hopper
- Multi operating control unit :  
32bit microprocessor in IP65 rated cabinet with 100 program setups

# Technical specifications

No. of loadcells/weigh heads :	16
Capacity :	Up to 80 weighings/Min. @ 1kg.
Weighing range:	200g. – 10kg.
Discharge volume:	10.000cc in single dump
Power supply:	380V, 50Hz, 16A
Compressed air:	6Bar, ± 400NI/Min. @ 50 weighings/Min.
Dimensions:	

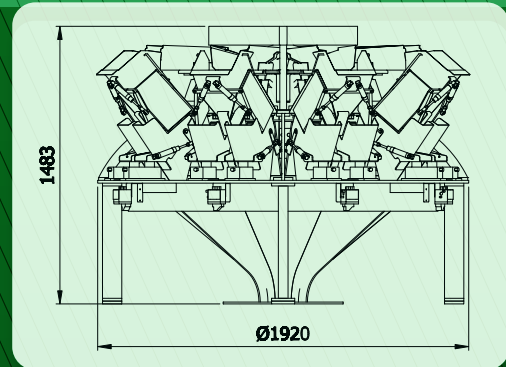

## High speed multihead weigher specially designed for potatoes.

